

RoHS Compliant

REV	DATE	DESCRIPTION	ECN NO.	NAME
A	20.09.22	PROPOSAL		JULY

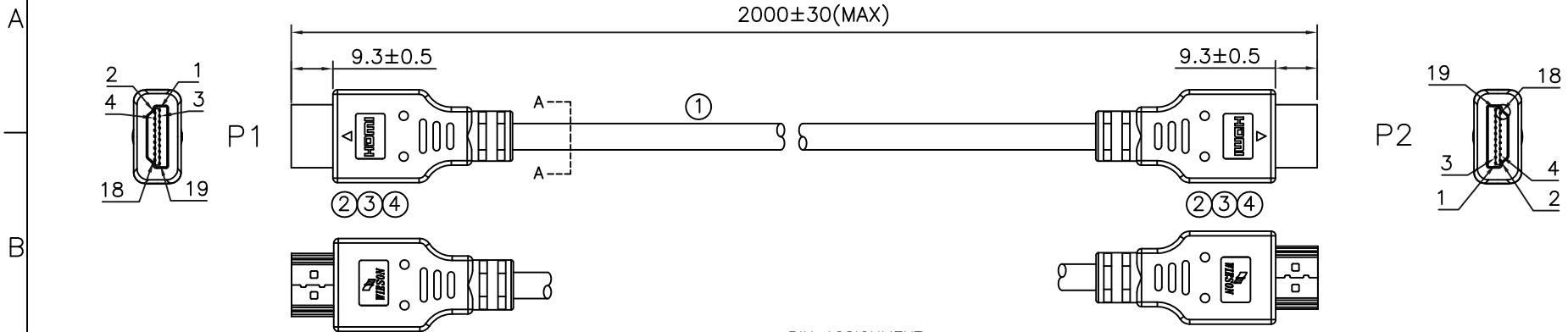

PIN ASSIGNMENT

P1	P2	AWG	GROUND	
1	1	30AWG	TMDS DATA 2+	1 PAIR+D.W
3	3	30AWG	TMDS DATA 2-	
2	2	30AWG	TMDS DATA 2 SHIELD	
4	4	30AWG	TMDS DATA 1+	1 PAIR+D.W
6	6	30AWG	TMDS DATA 1-	
5	5	30AWG	TMDS DATA 1 SHIELD	
7	7	30AWG	TMDS DATA 0+	1 PAIR+D.W
9	9	30AWG	TMDS DATA 0-	
8	8	30AWG	TMDS DATA 0 SHIELD	
10	10	30AWG	TMDS CLOCK+	1 PAIR+D.W
12	12	30AWG	TMDS CLOCK-	
11	11	30AWG	TMDS CLOCK SHIELD	
13	13	30AWG	CEC	1 CONDUCTOR
14	14	30AWG	RESERVED/HEAC+	1 PAIR+D.W
17	17	30AWG	DDC/CEC/HEAC GROUND	
19	19	30AWG	HOT PLUG DETECT/HEAC-	3 CONDUCTOR
16	16	30AWG	SDA	
15	15	30AWG	SCL	
18	18	30AWG	POWER +5V	
SHELL	SHELL		BRAID	

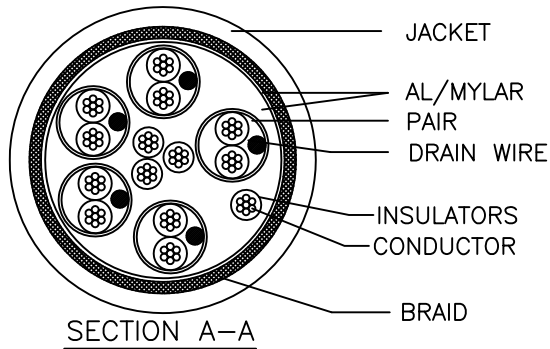

NOTES:

- P1 & P2 MODEL NUMBER:MLCW-HM-2204
MLCW-HM-1856.

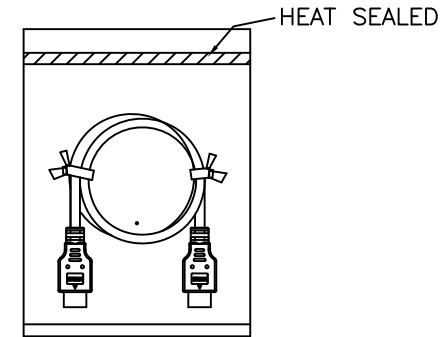

PACKING

CUST P/N.:

WIESON TECHNOLOGIES CO., LTD

PART NO.:
AB9856-01

TITLE:
HDMI2.1 A/M TO A/M CABLE

DRAWN BY	JULY (WSC)	DRAWING NO.	AB9856-01
CHECKED BY	HYP0	DRAWING SIZE	A4
APPROVED BY	JIM	UNIT	mm
SORTING NO.	WSC	PAGE	1 OF 1

NO.	ITEM	DESCRIPTION	QTY
④	OVER MOLD	MOLDING PVC 45P,COLOR:BLACK	AR
③	INNER MOLD	MOLDING PE,NATURAL COLOR.	AR
②	HDMI 19P MALE	HDMI 19PIN A TYPE MALE,BLACK,CONTACT:GOLD FLASH,SHELL NICKEL PLATED	2
①	CABLE	UL20276 [30AWG)*1P+DRAIN+AL-FOIL/MYLAR]*5C+30AWG*4C+AL-FOIL/MYLAR +BRAID(TC)+PVC JACKET, OD:6.0mm COLOR:BLACK(BC01)	1